

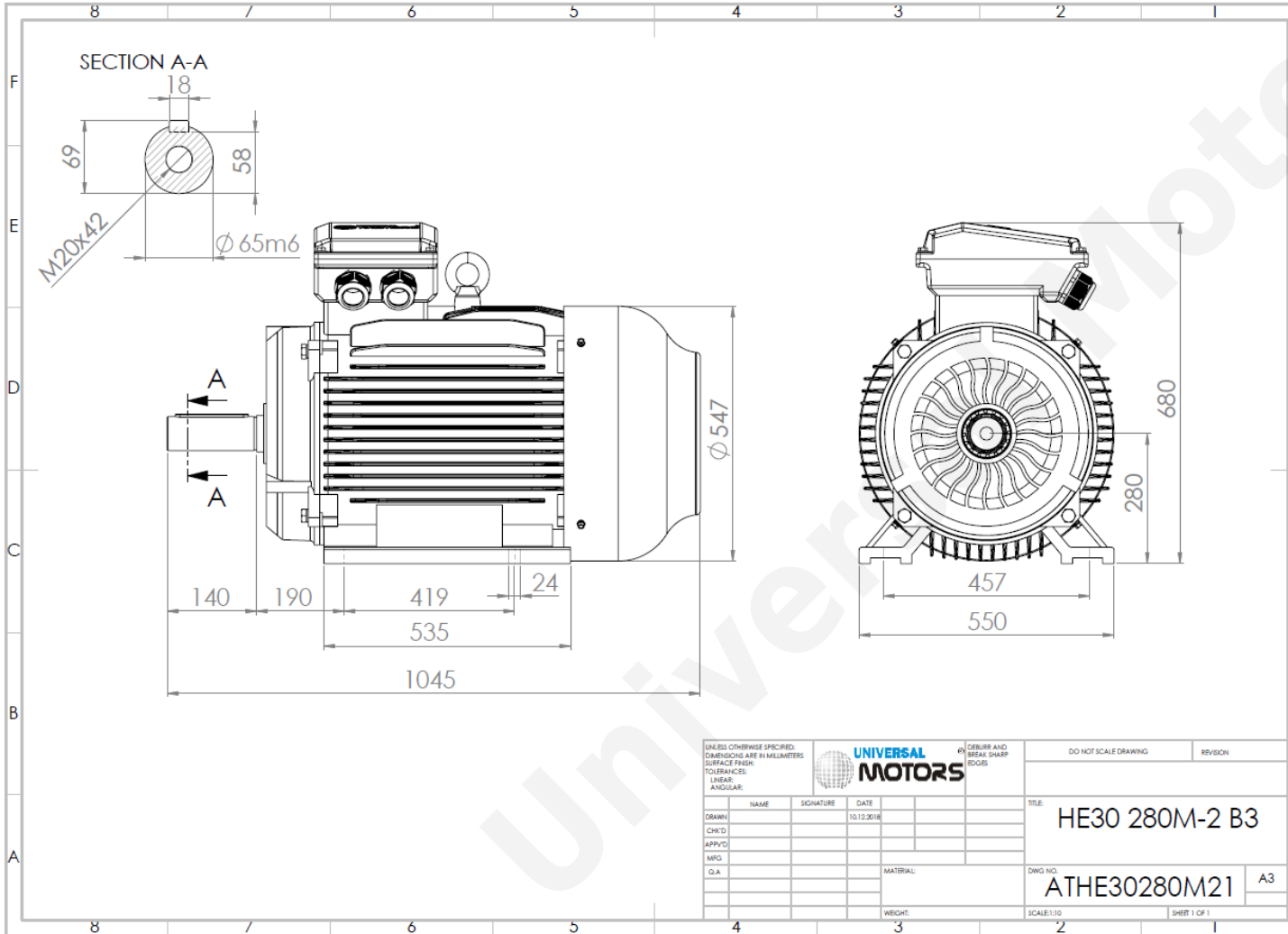

# TECHNICAL DATA

Three Phase Electric Motors - Cast Iron Frame  
 HE30 280 M-2 IE2  
 90 kW / 125 Cv  
 2975 RPM



Motor type:	<b>HE30 280 M-2 IE2</b>
Output:	<b>90 kW / 125 Cv</b>
Speed (min <sup>-1</sup> ):	<b>2975 RPM</b>
Frequency:	<b>50 Hz</b>
Voltage:	<b>400 V</b>
Current:	<b>155 A</b>
Power factor (Cos Ø):	<b>0.89</b>
Poles:	<b>2</b>
Insulation class:	<b>F</b>
Temperature rise Class:	<b>B</b>
Efficiency 50%:	<b>93.4 %</b>
Efficiency 75%:	<b>94.3 %</b>
Efficiency 100%:	<b>94.1 %</b>
Torque:	<b>289 N.m</b>
Tstarting/Tnominal:	<b>2.0</b>
Istarting/Inominal:	<b>7.0</b>
Tmaximum/Tnominal:	<b>2.3</b>
Noise:	<b>80 Db(A)</b>
Weight:	<b>570 Kg</b>
Bearing DE:	<b>6314 C3</b>
Bearing NDE:	<b>6314 C3</b>

UNLESS OTHERWISE SPECIFIED: DIMENSIONS ARE IN MILLIMETERS SURFACE FINISH: TOLERANCES: LINEAR: ANGULAR:				UNIVERSAL MOTORS		DO NOT SCALE DRAWING		REVISION	
DRAWN	NAME	SIGNATURE	DATE	TITLE:		DWG NO.:		SHEET 1 OF 1	
CHK'D			10.12.2018	HE30 280M-2 B3		ATHE30280M21		A3	
APP'VD									
MFG									
Q.A.									
				MATERIAL:		SCALE:1:10			
				WEIGHT:					

Regime - S1

Altitude - 1000m

Environment Temperature - 40°C

## CONTACTS:

UNIVERSAL MOTORS Tel: +351 252 299 080  
 Rua de São Brás,745 Fax: +351 252 299 089  
 4480-782 VILA DO CONDE Mail: [geral@universalmotors.pt](mailto:geral@universalmotors.pt)

\* References applied only in the UK